

HA2401G-500 - 500 mW 2.4 GHz 802.11g Outdoor WiFi Amplifier

HyperAmp® HA2401G-500 amplifiers are compatible with 802.11g (b/g) wireless LAN equipment. Hyperlink's Active Power Control circuit automatically adjusts the amplifier's gain to provide a constant output power regardless of cable length.



The HyperAmp® HA2401G series improves range by delivering full transmit power directly at the antenna where it is most effective. In addition the unit's receive gain compensates for cable losses. The unit can be configured to deliver the full transmit power with as little as 1 mW of input power, permitting cable runs of several hundred feet with no degradation in operating range.

This model features rugged, cast aluminum weather-proof construction to ensure years of reliable operation in the harshest environments. The integral mast mount gives this amplifier superior strength as well as simplifies installation. Included with the outdoor models, the DC Power Injector provides power to the HyperAmp® through the antenna cable, simplifying installation. Current-sensing circuits provide remote amplifier diagnostic LEDs. In addition, this unit provides effective lightning protection with multi-strike capability.

The power supply included with the amplifier is rated at 100-240 VAC @ 50/60 Hz allowing it to be used in the US as well as in the EU when used with the optional PSX-EU2 Plug converter (US NEMA 6-15R Flat Blades to EU 4/4.8 mm round pins).

Note:

This Hyperlink bi-directional amplifier is designed for burst half-duplex operation. It is not intended for constant transmit or CW operation. Operation of the amplifier in CW mode will damage the amplifier and void the warranty.

Guaranteed Quality

HyperAmp® is designed and manufactured in the U.S.A. and is backed by L-com's Limited Warranty

Features:

- IEEE 802.11g (b/g) Compatible
- Active Power Control
- N-Female Connectors
- Includes DC Injector and Mast-Mount Hardware
- 1 Year Limited Warranty

Applications:

- 2.4 GHz ISM Band Applications
- 802.11b and 802.11g WiFi Wireless LAN
- Public Wireless Hotspot

Specifications

Transmit Power	500 mW (27 dBm)
Receive Gain	15 dB nom
Frequency	2400 - 2500 MHz
Max. Input Power	100 mW (20 dBm)
Water Resistant Rating (Outdoor Models)	IEC 60529 IPX7
Operating Mode	Bi-directional, half-duplex Time Division Duplex. Senses RF carrier from transmitter and automatically switches from receive to transmit mode
Operating Temperature	-40°C to 50°C (-40°F to 122°F)
Dimensions	4.5 x 2.5 x 1.3 (inches) 117 x 64 x 33 (mm)
Weight	.68 lbs. (.30 Kg)
Current Draw	0.80A Peak Tx and 0.06A Peak Rx
Supply Voltage	9-12VDC +/-1V

FCC Certification Support for OEMs

HyperLink offers full certification assistance services and engineering support for qualifying OEM's interested in certifying complete amplified WLAN systems. Please contact us for details

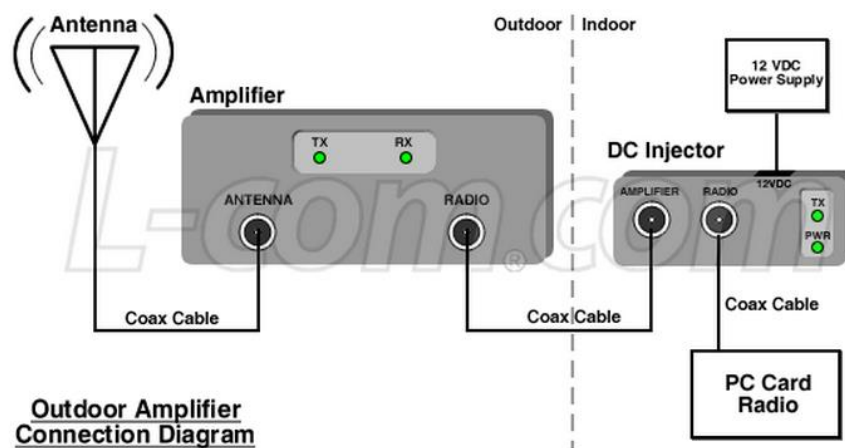

Copyright © Hyperlink Technologies, Inc.
all rights reserved

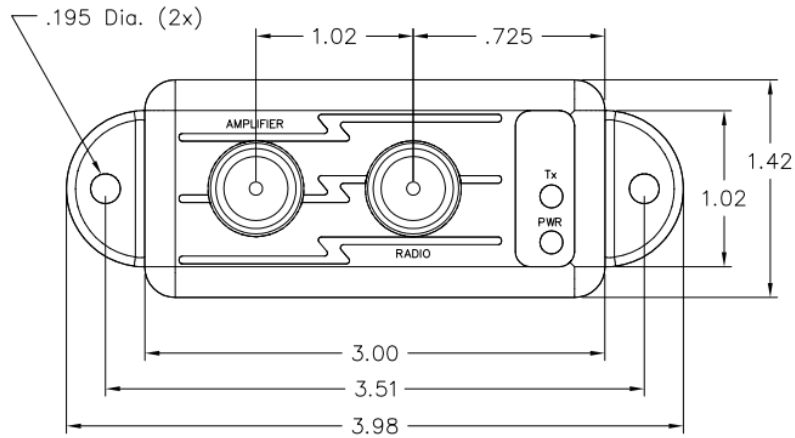
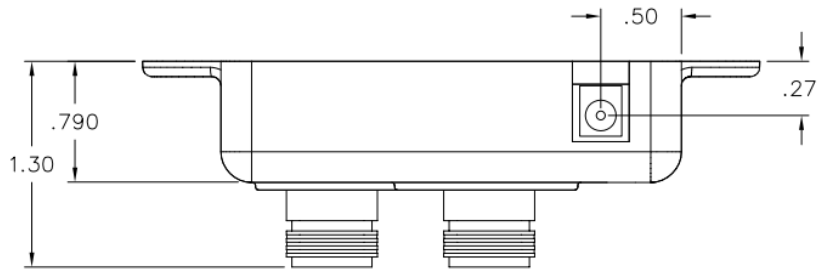
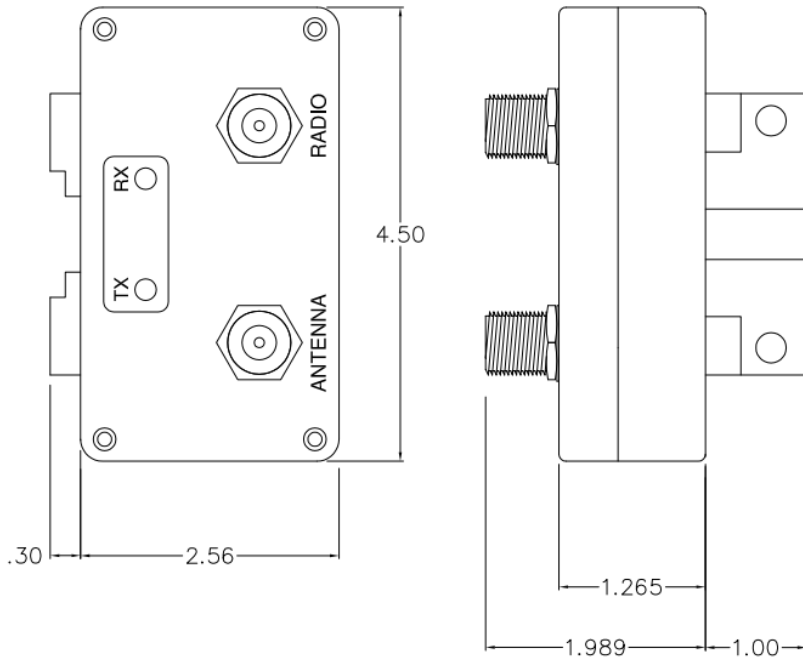

ALL DIMENSIONS IN INCHES