

Smart Power Sensor

PWR-8P-RC

50Ω -60 dBm to +20 dBm, 10 to 8000 MHz

The Big Deal

- Peak & average power of CW & pulse waveforms with pulse profiling
- Measures power levels down to -60 dBm
- Sample rate 500,000 samples per sec.
- **USB and Ethernet control**

Typical Applications

- Pulse profiling & statistical signal analysis
- Radar characterization (VHF / UHF / L / S / C bands)
- Particle accelerator experimentation
- Signal level calibration in production test systems
- Power monitoring in remote installations / base-stations

Product Overview

Mini-Circuits' PWR-8P-RC is a compact sensor-head that turns any PC into a high performance power meter for peak and average measurements of CW and pulse modulated signals. The sensor has an 80 dB input dynamic range and wide bandwidth, allowing measurement of RF powers down to -60 dBm over 10 to 8000MHz.

The USB HID interface is "plug & play" compatible, meaning no driver installation is required, while the additional Ethernet interface allows remote power measurements over a network. Full software support is provided, including our user-friendly GUI application for Windows and a full API with programming instructions for Windows and Linux environments (both 32-bit and 64-bit systems). Download the software package from <http://www.minicircuits.com/softwaredownload/pm.html>

Key Features

| Feature | Advantages |
|--|---|
| Peak, average and pulse profiling | Measure peak & average power of CW and pulsed signals. Analyze and graphically plot the peak & average power, duty cycle, pulse width, crest factor, rise & fall times of pulsed signals. |
| Wide dynamic range (80 dB) | Measure as low as -60 dBm and as high as +20 dBm with a single sensor, opening up a wide range of applications and reducing the need for external gain / attenuation control circuits |
| External trigger controls and video output | Trigger in and out ports support precise synchronization with external test equipment and allow capture of irregular signal patterns and pulses. Video output allows the sensor to be used in ALC loops |
| Very low duty cycles | Capable of measuring pulses as short as 10 μs with duty cycles as low as 0.001% |
| No user calibration required | Accurate power measurements can commence as soon as the sensor is connected since it does not require any zero or reference measurements |
| Excellent impedance match | Input VSWR of 1.15:1 typ reduces measurement errors due to impedance mismatch |

Trademarks: Windows is a registered trademark of Microsoft Corporation in the United States and other countries. Linux is a registered trademark of Linus Torvalds. Mac is a registered trademark of Apple Corporation. Pentium is a registered trademark of Intel Corporation. Neither Mini-Circuits nor the Mini-Circuits PWR-series power sensors are affiliated with or endorsed by the owners of the above referenced trademarks

Mini-Circuits and the Mini-Circuits logo are registered trademarks of Scientific Components Corporation.



Software Package

CASE STYLE: JL2441

| Model No. | Description |
|-----------------------------|--------------------------------|
| PWR-8P-RC | USB smart Power Sensor |
| Included Accessories | |
| PWR-SEN-8P-RC | Power Sensor Head |
| USB-CBL-AB-7+ | 6.8 ft USB cable |
| CBL-5FT-BMSMB+ | BNC(M) to SMB(F) Trigger cable |
| NF-SM50+ | N-Type (F) to SMA(M) Adapter |

RoHS Compliant

See our web site for RoHS Compliance methodologies and qualifications

Electrical Specifications, -60 dBm to +20 dBm, 10 to 8000 MHz

| Parameter | | Freq. Range (MHz) | Min. | Typ. | Max. | Units |
|--|--------------------------------------|-------------------|-------|-------|--------|-------|
| Dynamic range ¹ | | 10 - 8000 | -60 | - | +20 | dBm |
| VSWR | | 10 - 8000 | - | 1.15 | 1.25 | :1 |
| Uncertainty of power measurement ^{2,3} @ 25°C | @ -60 to -50 dBm | 10 - 4000 | - | ±0.10 | ±0.35 | dB |
| | | 4000 - 8000 | - | ±0.10 | ±0.40 | dB |
| | @ -50 to 0 dBm | 10 - 4000 | - | ±0.10 | ±0.35 | dB |
| | | 4000 - 8000 | - | ±0.10 | ±0.40 | dB |
| | @ 0 to +20 dBm | 10 - 4000 | - | ±0.10 | ±0.40 | dB |
| | | 4000 - 8000 | - | ±0.10 | ±0.40 | dB |
| Uncertainty of power measurement ^{2,3} @ 0°C to 50°C | @ -55 to -50 dBm | 10 - 4000 | - | ±0.20 | - | dB |
| | | 4000 - 8000 | - | ±0.35 | - | dB |
| | @ -50 to 0 dBm | 10 - 4000 | - | ±0.10 | - | dB |
| | | 4000 - 8000 | - | ±0.15 | - | dB |
| | @ 0 to +20 dBm | 10 - 4000 | - | ±0.10 | - | dB |
| | | 4000 - 8000 | - | ±0.10 | - | dB |
| Linearity @ 25°C | | 10 - 8000 | - | 2.0 | - | % |
| Measurement resolution | | 10 - 8000 | 0.01 | - | - | dB |
| Averaging range | | 10 - 8000 | 1 | - | 999 | - |
| Sample period | @ full sampling rate | 10 - 8000 | 0.01 | - | 2.5 | ms |
| | @ reduced sampling rate ⁴ | 10 - 8000 | - | - | 1000 | |
| Time base accuracy | | - | - | - | 30 | ppm |
| Max sample rate @ sample period ≤2.5 ms ⁵ | | 10 - 8000 | - | 500 | - | ksps |
| Pulse profiling bandwidth | | 10 - 8000 | - | - | 100 | kHz |
| Minimum pulse width | | 10 - 8000 | - | 5 | 10 | µs |
| Minimum measurable rise/fall time ⁶ | | 10 - 8000 | - | - | 4 | µs |
| Pulse duty cycle for pulse profiling ⁴ | | 10 - 8000 | 0.001 | - | 99.999 | % |
| Video output frequency | | - | DC | - | 10 | MHz |
| DC current | @ USB control | 10 - 8000 | - | 400 | 450 | mA |
| | @ Ethernet control ⁷ | | - | 540 | 600 | |
| Trigger in voltages | Logic High | - | 2.4 | - | 5 | V |
| | Logic Low | - | 0 | - | 0.6 | |
| Trigger out voltages | Logic High | - | 3 | - | 5 | |
| | Logic Low | - | 0 | - | 0.3 | |
| Video out@50 Ω load | Output voltage | - | 0.5 | - | 2.2 | |

¹ Maximum continuous safe operational power limit: +23 dBm. Power sensor is usable 10-10000 MHz range but performance is guaranteed only over 10-8000 MHz
² Tested with CW signal
³ Power uncertainty is specified for default sample period of 10ms.
⁴ As sample period increases above 2.5 ms, resolution will decrease. If measuring a signal with duty cycle below 0.1% or over 99.9%, use the 'Zoom on Pulse' function in Pulse Profiling to get accurate peak and average measurements.
⁵ Max sample rate is measured in thousands of samples per second (ksps). With sample periods greater than 2.5 msec the sample rate will be reduced to allow covering the full sample period.
⁶ sensor's internal rise time of 2.5 µs contributes an error to the measured rise time up to $M_{max} = \sqrt{(R^2 + 6.25)}$ where R is the real rise time of the signal and M is the measured rise time indicated by the sensor, so for example a signal with a 6µs rise may produce a measured rise time of up to $\sqrt{(\text{signal rise time}^2 + \text{sensor rise time}^2)} = \sqrt{(6^2 + 2.5^2)} = 6.5\mu\text{s}$ (8.3% measurement error in rise time)
⁷ When using Ethernet control, it is recommended to use a power adaptor (USB-AC/DC-5+ or eqv), a powered hub, or USB 3.0 port to supply power as some USB 2.0 ports may not be able to provide the power required.

Absolute Maximum Ratings

| Parameter | Ratings |
|-----------------------|---------------|
| Operating Temperature | 0°C to 50°C |
| Storage Temperature | -30°C to 70°C |
| DC Voltage at RF port | 25 V |
| Trigger In | -0.3V to 5.5V |
| CW Power | +26 dBm |

Connections

| | |
|------------------------|---------------------|
| RF Input | (N Type-Male) |
| Trigger In | (SMB-Male) |
| Trigger Out | (SMB-Male) |
| USB Port | (USB type B female) |
| Network (Ethernet/LAN) | (RJ45 socket) |

Outline Drawing (JL2441)

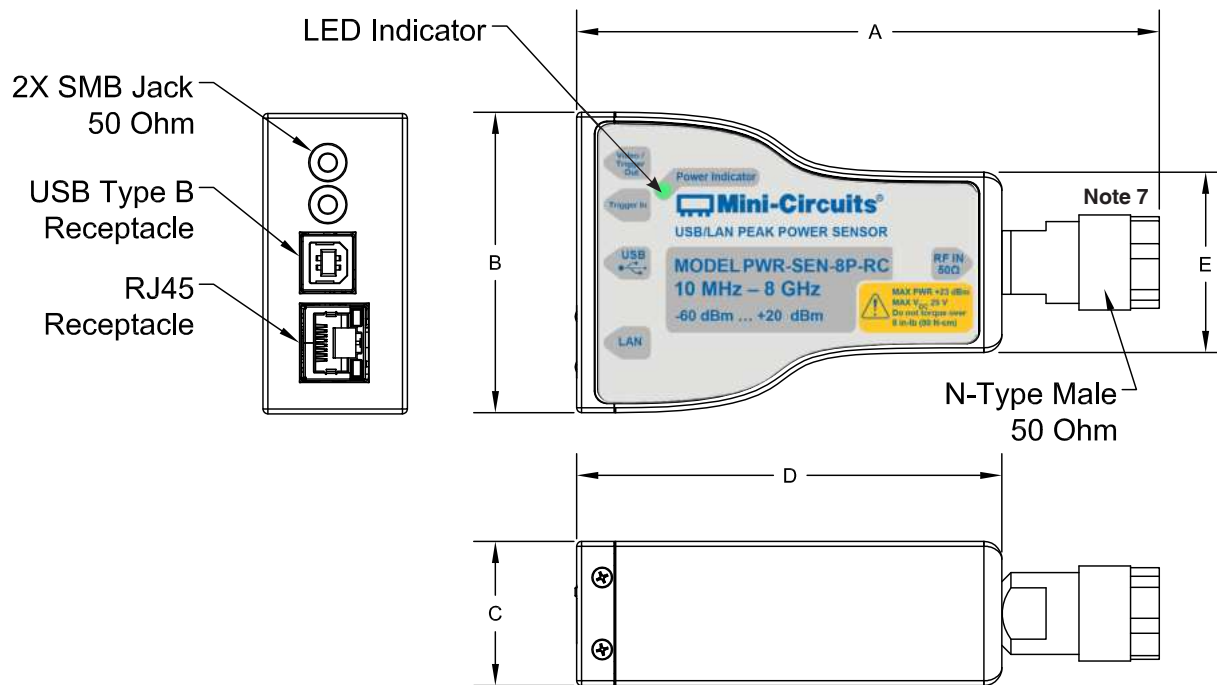

Outline Dimensions (inches/mm)

| A | B | C | D | E | WT. GRAMS |
|-------|------|------|------|------|-----------|
| 4.85 | 2.50 | 1.20 | 3.54 | 1.5 | 260 |
| 123.1 | 63.5 | 30.5 | 89.9 | 38.1 | |

⁷ Maximum torque 8 in-lb (90 N-cm).

Typical Performance Curves

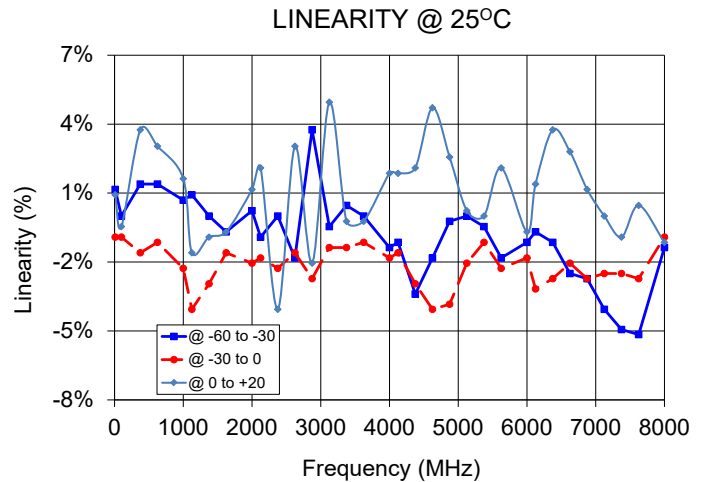
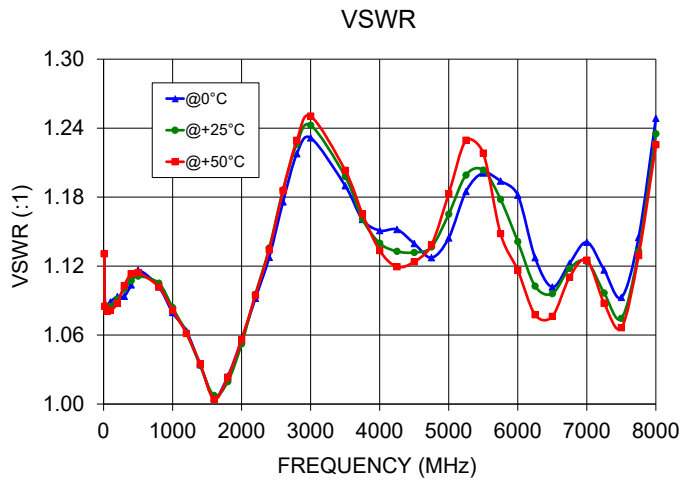
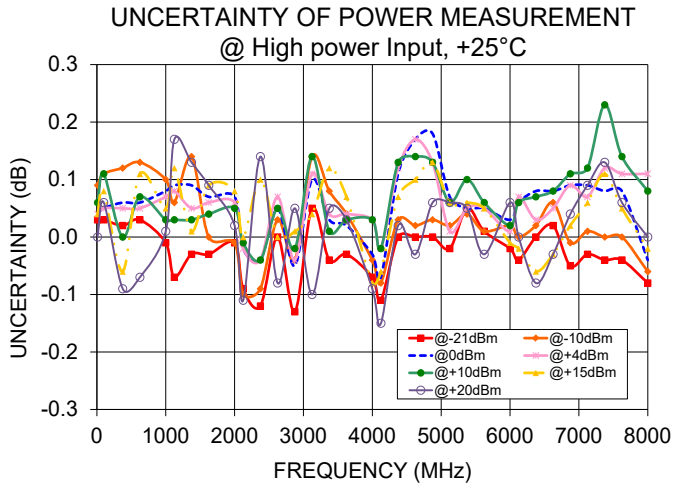
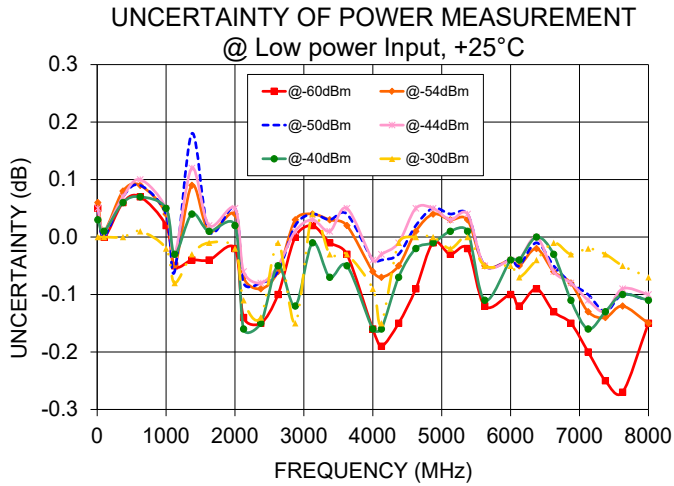

Software & Documentation Download:

- Mini-Circuits' full software and support package including user guide, Windows GUI, DLL files, programming manual and examples can be downloaded free of charge from <http://www.minicircuits.com/softwaredownload/pm.html>.
- Please contact testsolutions@minicircuits.com for support

Minimum System Requirements

| Parameter | Requirements | |
|--------------------------|--|--|
| Interface | USB HID or HTTP Get/Post or Telnet protocols | |
| System requirements | GUI: | Windows 32 & 64 bit systems from Windows 98 up to Windows 10 |
| | USB API (ActiveX & .Net) | Windows 32 & 64 bit systems with ActiveX or .Net support from Windows 98 up to Windows 10 |
| | USB direct programming support | Linux, Windows systems from Windows 98 up to Windows 10 |
| | Telnet & HTTP | Any Windows, Mac, or Linux computer with a network port and Ethernet-TCP/IP (HTTP or Telnet protocols) support |
| Hardware | Pentium® II or higher, RAM 256 MB | |
| Control cable (supplied) | Power sensor to be used with the supplied USB cable only | |

Graphical User Interface (GUI) for Windows

Key Features:

- Set compensation frequency and monitor power measurement
- Configure measurement (offsets, relative power readings, averaging, etc.)
- Peak and average power measurement
- Pulse profiling (see [user guide](#) and page 6 for details)
- Internal and external trigger, Trigger and Video outputs
- Graphical pulse display with 'zoom on pulse' feature (see [user guide](#) and page 6 for details)
- Control multiple power sensors at once
- Schedule data recording

Note: Main screen power measurement will be accurate only for duty cycle 99.9% to 0.1%, for duty cycles outside this range need to use the 'Zoom on Pulse' function in Pulse Profiling.



Enable pulse profiling and graphical pulse display, see page 6 for details

Application Programming Interface (API)

Windows Support:

- API DLL files exposing the full power sensor functionality
 - ActiveX COM DLL file for creation of 32-bit programs
 - .Net library DLL file for creation of 32 / 64-bit programs
- HTTP Get/Post and Telnet protocols use SCPI commands to provide full control.
- Supported by most common programming environments (refer to application note [AN-49-001](#) for summary of tested environments)

Linux Support:

- Full power sensor control in a Linux environment is achieved by way of USB interrupt commands.



Graphical User Interface - Pulse Profiling Features

- Set the sample period between 10µs and 1s to capture the pulse profile
- Select from 4 trigger options:
 1. Free – No trigger / free running measurements
 2. Internal – Detect and stabilise the measurements on the rising edge of the RF signal
 3. External
 - a. Rising edge – Measurements are triggered on the rising edge of an external trigger signal
 - b. Falling edge – Measurements are triggered on the falling edge of an external trigger signal
- Enable external trigger / video output if required:
 - a. External trigger provides a TTL output on the rising edge of a pulse for synchronization with external measurement equipment
 - b. Video output allows wider bandwidth pulses to be recorded by external measurement equipment

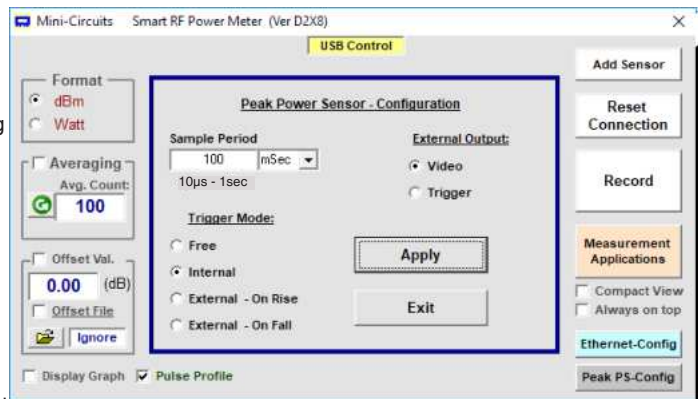

Fig 1: Main screen in Pulse Profiling configuration mode

The main pulse profile display shows the full sample period of the sensor in the time domain. Up to four markers can be set as required to measure power levels and calculate time / power deltas

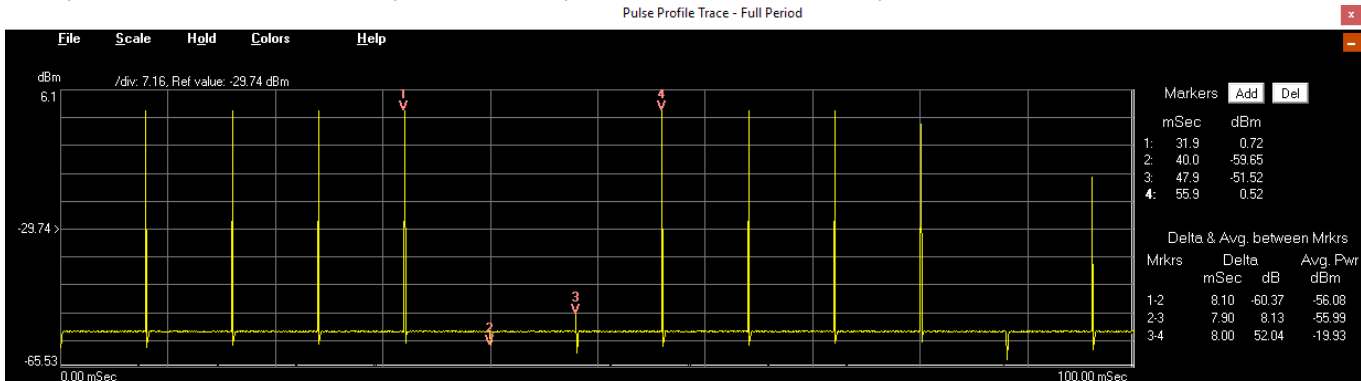

Fig 2: Graphical Pulse Profile - Full sample period

“Zoom on pulse” feature will automatically zoom on the first identified pulse and allows any portion of the pulse profile to be focused on / expanded in a second graphical display, simply by ‘right clicking’ and dragging the mouse cursor over relevant section of the profile.

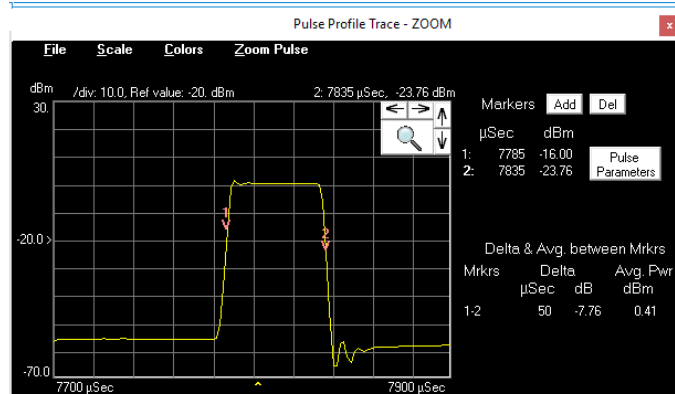

Fig 3: Graphical Pulse Profile - “Zoom on Pulse”

For signals with duty cycle greater than 99.9% or under 0.1% the automatic ‘zoom on pulse’ may not work - in such cases you can adjust the zoom window by clicking on the arrow icons to increment/decrement the trigger delay and span, or the magnifying glass to type in precise values

| Parameter | Value |
|---------------------|--------|
| Pulse Width (mSec) | 0.044 |
| Pulse Period (mSec) | 8.020 |
| Duty Cycle (%) | 0.55 |
| Rise Time (µs) | 3.54 |
| Fall Time (µs) | 3.54 |
| Pulse Pwr (dBm) | 0.75 |
| Cycle Avg. (dBm) | -19.70 |
| Crest Factor (dB) | 20.45 |
| Over Shoot (dB) | 0.98 |

Fig 4: Calculated Pulse parameters

Full pulse parameters are calculated and displayed in tabular form, including peak / average power, pulse width / period, duty cycle, rise / fall time, crest factor and overshoot.

Note: If ‘zoom on pulse’ window is not showing the pulse signal calculated parameter may not be correct

Connection diagrams

Connection diagram for USB control

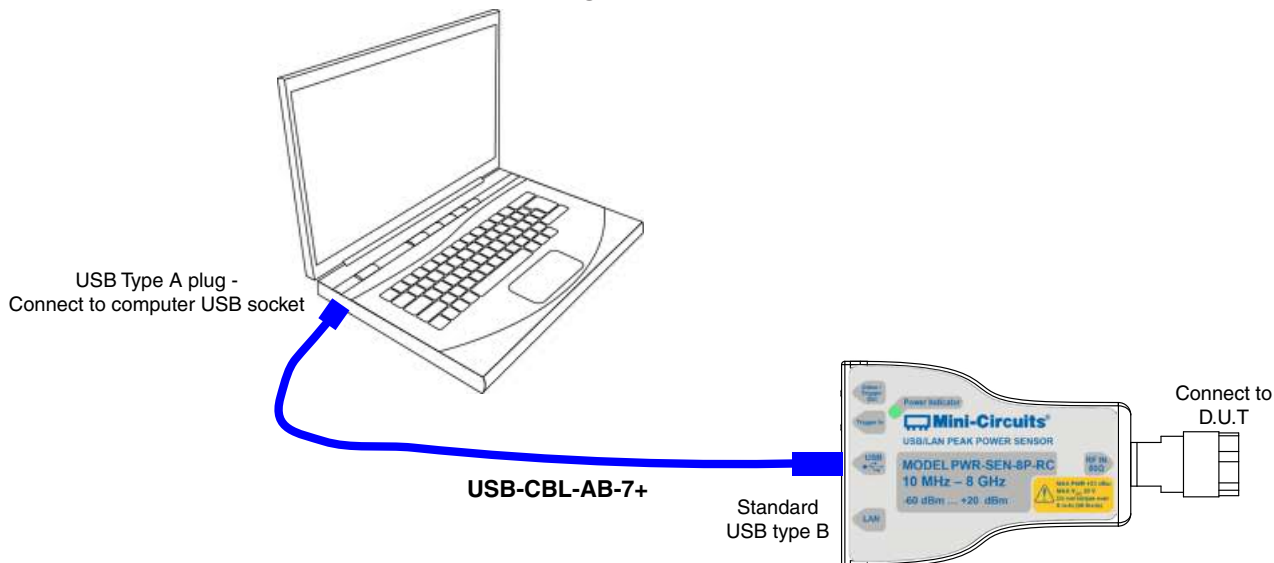

Connect USB-AC/DC-5 to mains power

Connection diagram for Ethernet control, using power adaptor

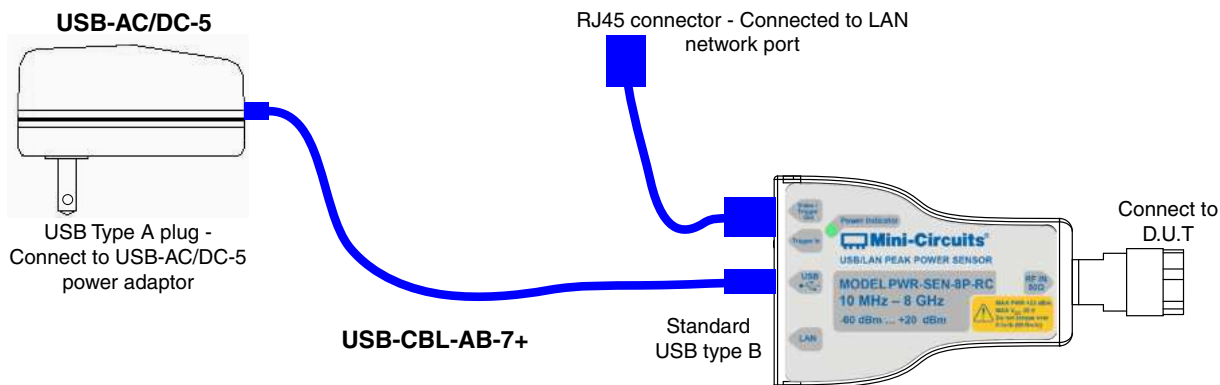



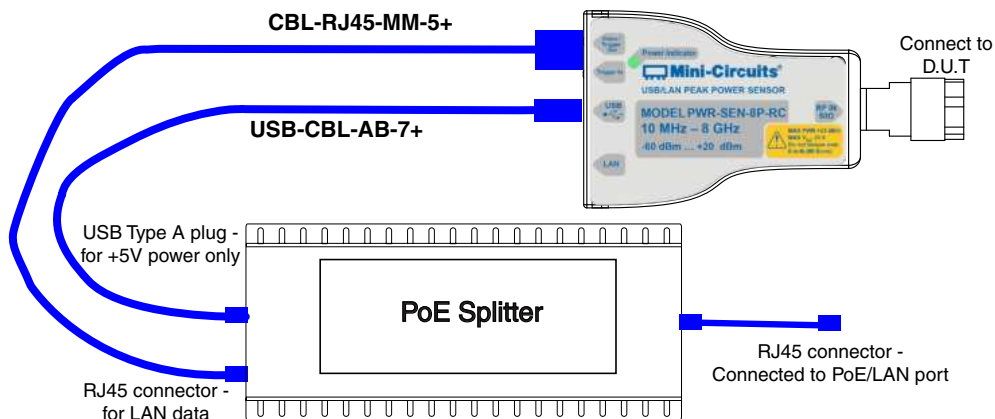

Connection diagram for Ethernet control, using PoE system

Note: Commercially available PoE splitter not supplied by Mini-Circuits



Ordering Information

| Model | Description |
|-----------|---|
| PWR-8P-RC | USB/Ethernet <i>Smart</i> Peak & Average Power Sensor |

| Included Accessories | Part No. | Description |
|---|----------------|--|
|  | PWR-SEN-8P-RC | Power Sensor Head |
|  | USB-CBL-AB-7+ | 6.8 ft (2.1 m) USB Cable: USB type A(Male) to USB type B(Male) |
|  | CBL-5FT-BMSMB+ | 5 ft (1.5 m) Trigger cable: BNC(male) to SMB(Female) |
|  | NF-SM50+ | N-Type Female to SMA Male Adapter. |

| Optional Accessories | Description |
|-----------------------|---|
| USB-AC/DC-5 | AC/DC 5V _{DC} Power Adapter with US, EU, IL, UK, AUS, and China power plugs ^{8,9} |
| USB-CBL-AB-3+ | 2.7 ft (0.8 m) USB Cable: USB type A(Male) to USB type B(Male) |
| USB-CBL-AB-7+ (spare) | 6.8 ft (2.1 m) USB Cable: USB type A(Male) to USB type B(Male) |
| CBL-RJ45-MM-5+ | 5 ft (1.5 m) Ethernet cable: RJ45(Male) to RJ45(Male) Cat 5E cable |
| CBL-5FT-BMSMB+(spare) | 5 ft (1.5 m) Trigger cable: BNC(male) to SMB(Female) |
| NF-SM50+ (spare) | N-Type Female to SMA Male Adapter. |
| NF-SF50+ | N-Type Female to SMA Female Adapter |
| NF-BM50+ | N-Type Female to BNC Male Adapter. |

⁸ Power plugs for other countries are also available, if you need a power plug for a country not listed in the table please contact testsolutions@minicircuits.com for support.

⁹ Power adaptor, powered hub or USB 3.0 port may be used to provide power when in Ethernet control, not needed in USB control.

| Calibration | Description |
|--------------|--|
| CALSEN-8P-RC | Calibration Service Click Here |

Additional Notes

- A. Performance and quality attributes and conditions not expressly stated in this specification document are intended to be excluded and do not form a part of this specification document.
- B. Electrical specifications and performance data contained in this specification document are based on Mini-Circuit's applicable established test performance criteria and measurement instructions.
- C. The parts covered by this specification document are subject to Mini-Circuits standard limited warranty and terms and conditions (collectively, "Standard Terms"); Purchasers of this part are entitled to the rights and benefits contained therein. For a full statement of the Standard Terms and the exclusive rights and remedies thereunder, please visit Mini-Circuits' website at www.minicircuits.com/MCLStore/terms.jsp

